

# SAMPLER SNEEZE GUARD



•Designed for use in grocery store/wholesale club food sampling, continental breakfast's, and to cover condiments.

SAMPLER GUARD



*Protect your investment, ensure proper storage and handling.  
Storage and handling solutions are available.*



ANSI/NSF 2

\* Images are computer renderings, not actual photos, some color variance may occur from what is rendered to the actual powder coat finish.

Phone: 800-569-2056  
Fax: 573-449-7126  
[www.sneezeguardsolutions.com](http://www.sneezeguardsolutions.com)

# SPECIFICATIONS

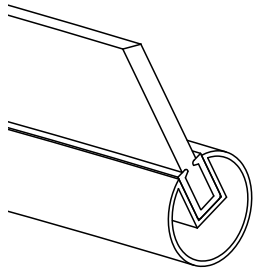
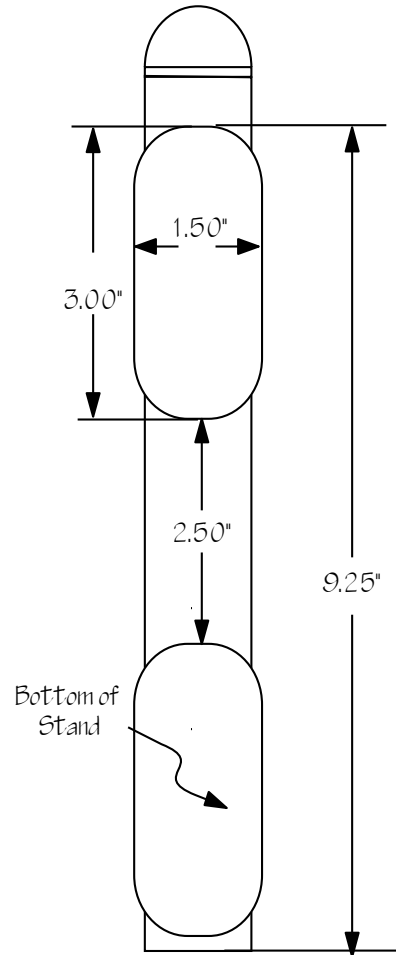
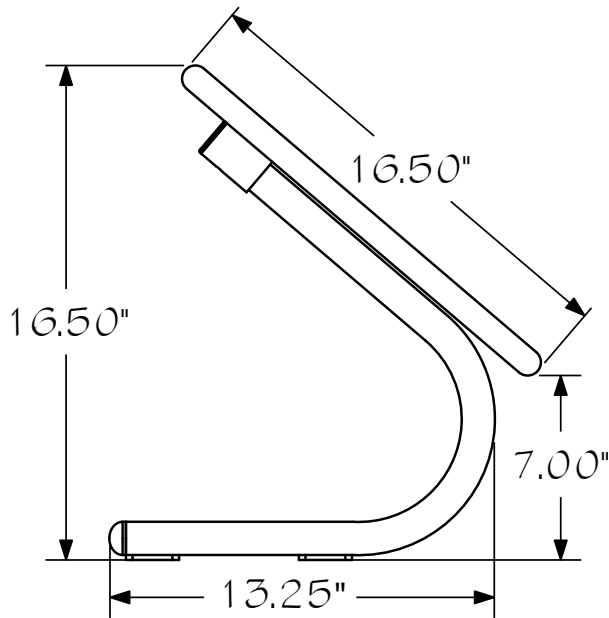

- Exclusive extruded 1" Groove Tube
- Mounted in rubber gasket
- 1.25" aluminum stands
- Scratch resistant acrylic food shield
- Powder coated finish

<i>Black</i>	<i>Nominal Length</i>	<i>Overall Length</i>	<i>Between Stands</i>	<i>Weight</i>
6001	2 foot	25.5"	20.5"	6 lbs
6101	3 foot	34.75"	29.75"	8 lbs

SAMPLER GUARD