

ANGLED DIVIDER STATIONARY SNEEZE GUARD

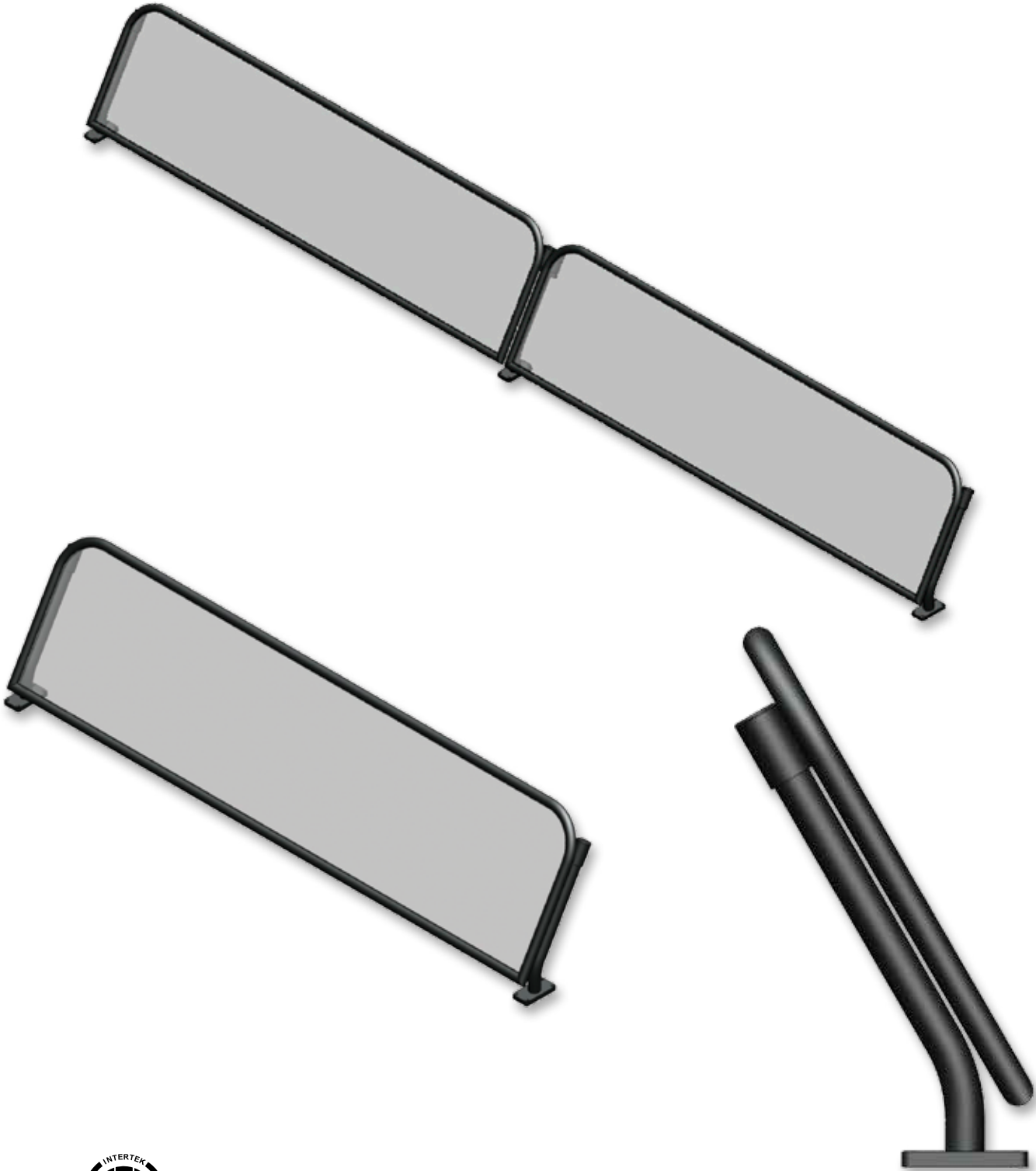

ANGLED DIVIDER STATIONARY



ANSI/NSF 2

* Images are computer renderings, not actual photos, some color variance may occur from what is rendered to the actual powder coat finish.

Phone: 800-569-2056

Fax: 573-449-7126

www.sneezeguardsolutions.com

SPECIFICATIONS

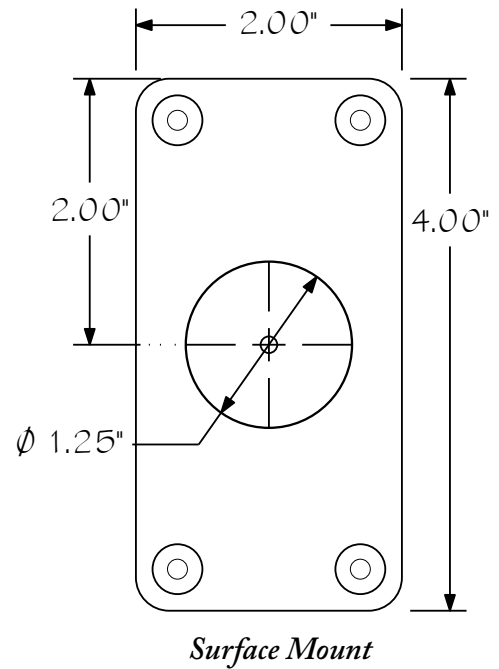
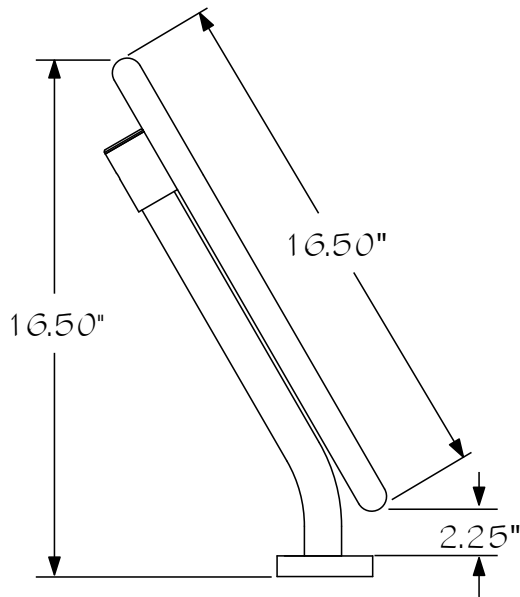

ANGLED DIVIDER STATIONARY

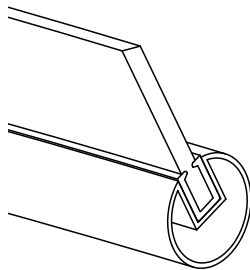

- Exclusive extruded 1" Groove Tube
- Mounted in rubber gasket
- 1.25" aluminum stands
- Scratch resistant acrylic food shield
- Powder coated finish

<i>Black</i>	<i>Gold</i>	<i>Nominal Length</i>	<i>Overall Length</i>	<i>Between Stands</i>	<i>Weight</i>
<i>2091 DA</i>	<i>2092 DA</i>	<i>2 foot</i>	<i>25"</i>	<i>21"</i>	<i>6 lbs</i>
<i>2101 DA</i>	<i>2102 DA</i>	<i>3 foot</i>	<i>34.25"</i>	<i>30.25"</i>	<i>7 lbs</i>
<i>2201 DA</i>	<i>2202 DA</i>	<i>4 foot</i>	<i>46.25"</i>	<i>42.25"</i>	<i>9 lbs</i>
<i>2301 DA</i>	<i>2302 DA</i>	<i>5 foot</i>	<i>58.25"</i>	<i>54.25"</i>	<i>11 lbs</i>
<i>2401 DA</i>	<i>2402 DA</i>	<i>6 foot</i>	<i>70.25"</i>	<i>66.25"</i>	<i>13 lbs</i>
<i>2481 DA</i>	<i>2482 DA</i>	<i>8 foot</i>	<i>94.25"</i>	<i>90.25"</i>	<i>17 lbs</i>

Call for quote on substituting acrylic for tempered glass food shield.

Silver available upon request.